

A · HISTORY · OF · ARCHITECTURE
ON · THE · COMPARATIVE · METHOD
SIR · BANISTER · FLETCHER

S. ANDREW: HECKINGTON LINCS.

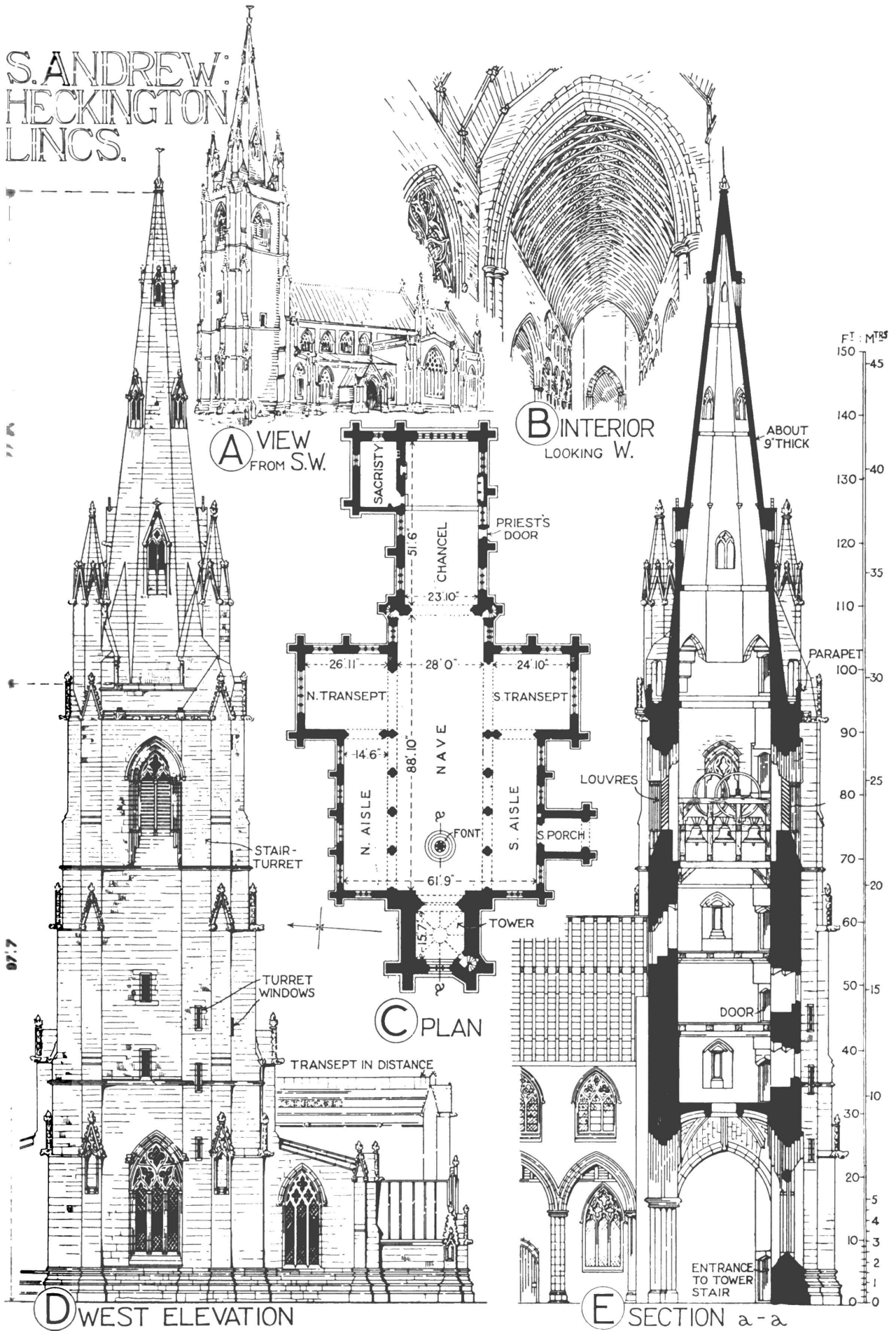

MEDIÆVAL CROSSES & TITHE BARN

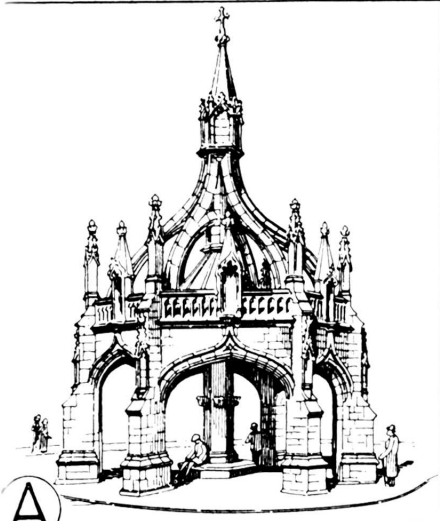

A CITY CROSS: SALISBURY

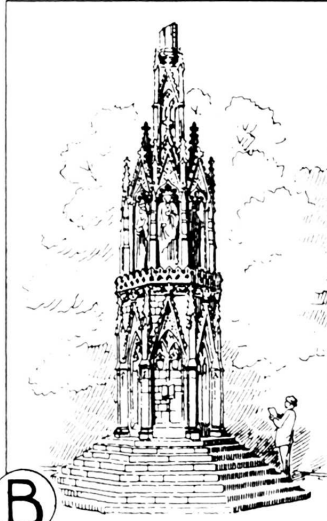

B ELEANOR +: NORTHAMPTON

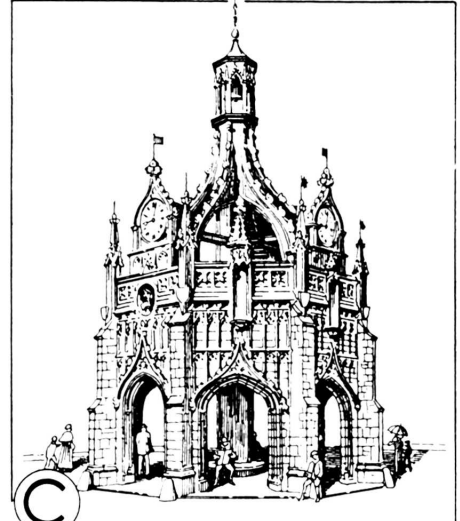

C MARKET CROSS: CHICHESTER

THE ABBOT'S BARN: GLASTONBURY



D EXTERIOR FROM S.W.

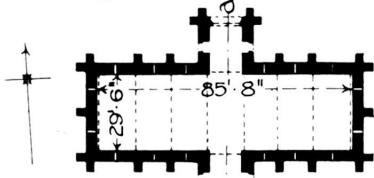

E PLAN

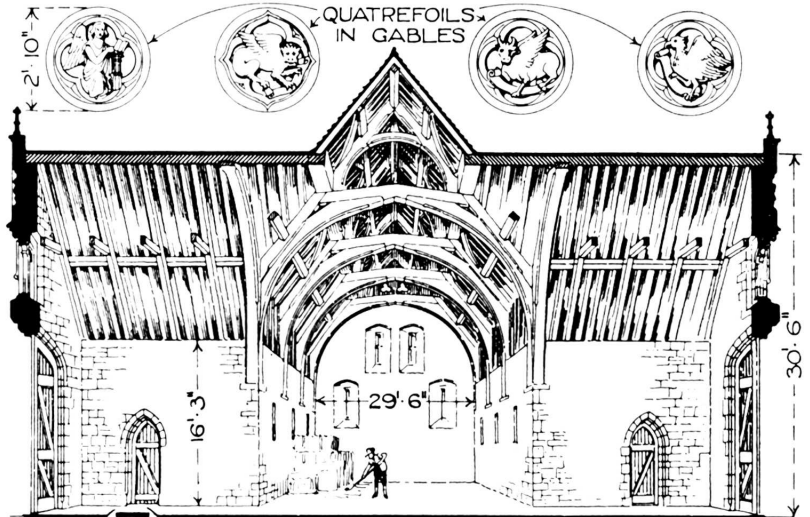

F SECTIONAL INTERIOR ON a-a

OLD BARN: FULLSTONE FARM: KENT

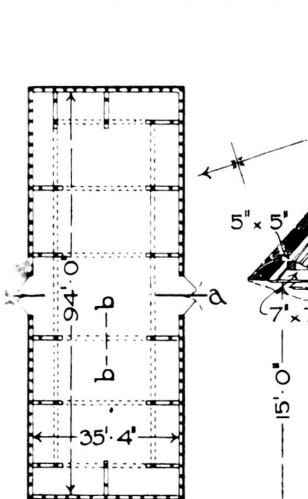

G PLAN

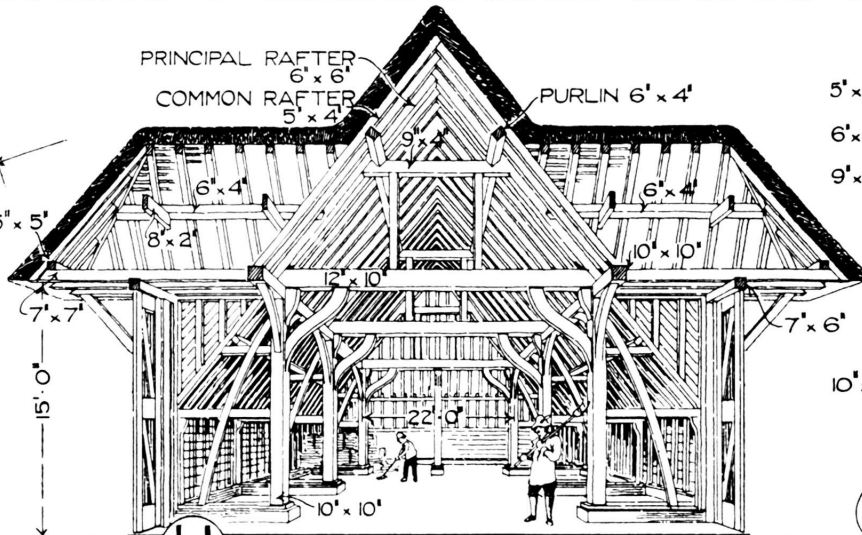

H SECTIONAL INTERIOR ON a-a

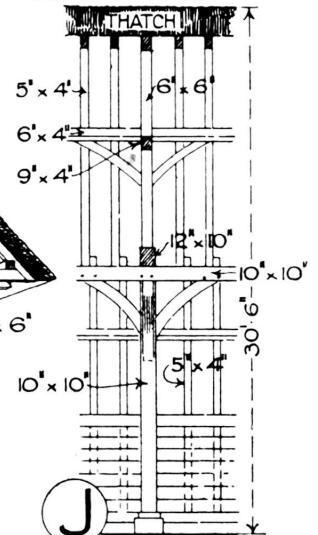

J DETAIL AT b-b

EVOLUTION OF CHURCH PLANS

ANGLO-SAXON

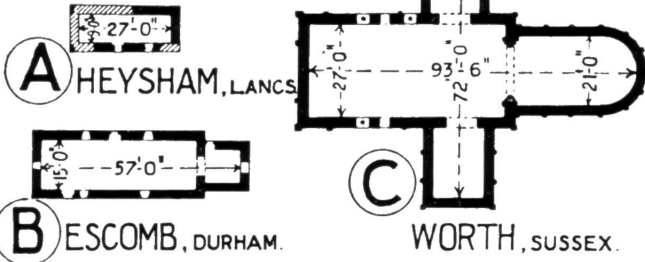

NORMAN

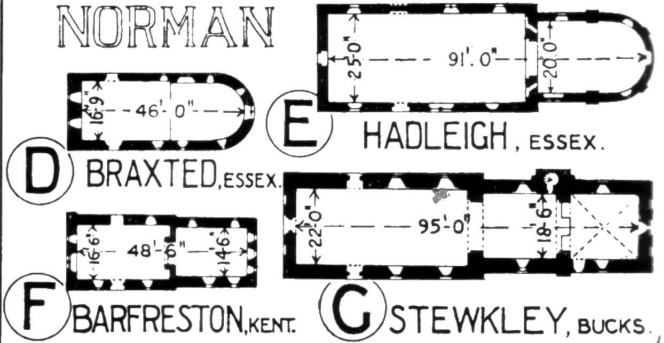

EARLY ENGLISH

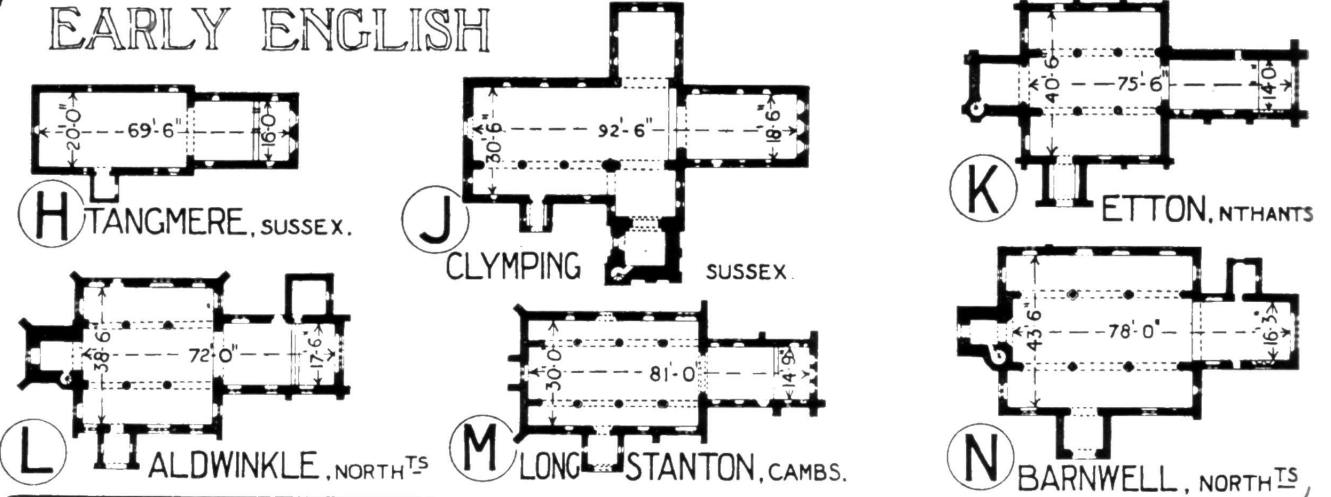

DECORATED

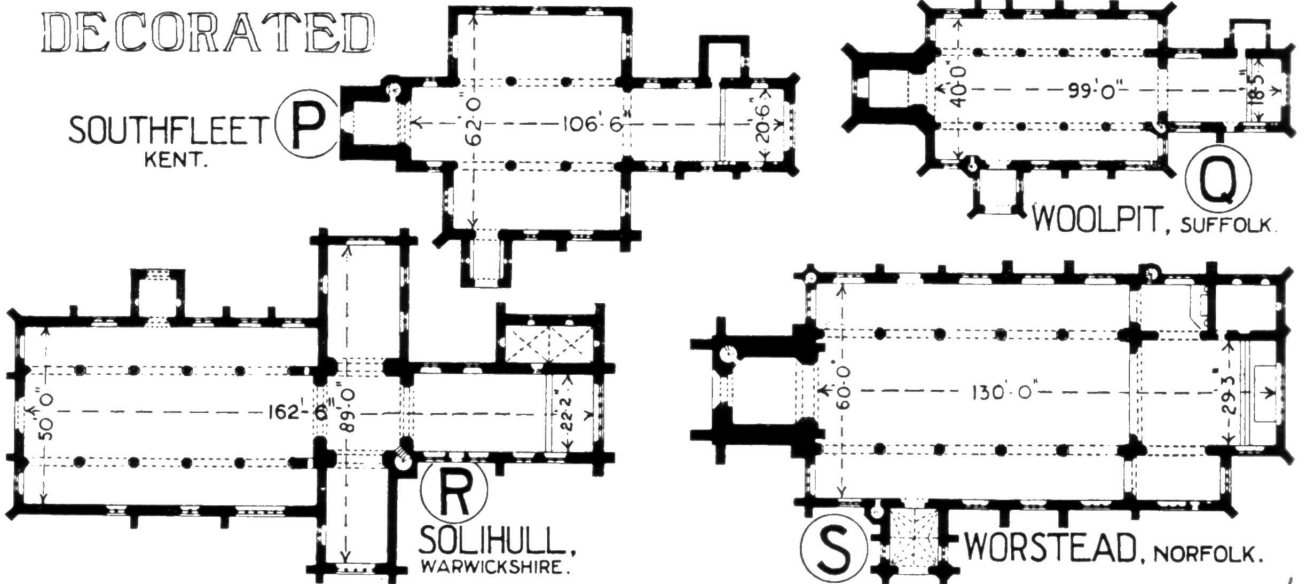

PERPENDICULAR

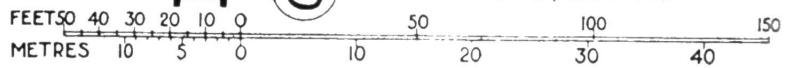
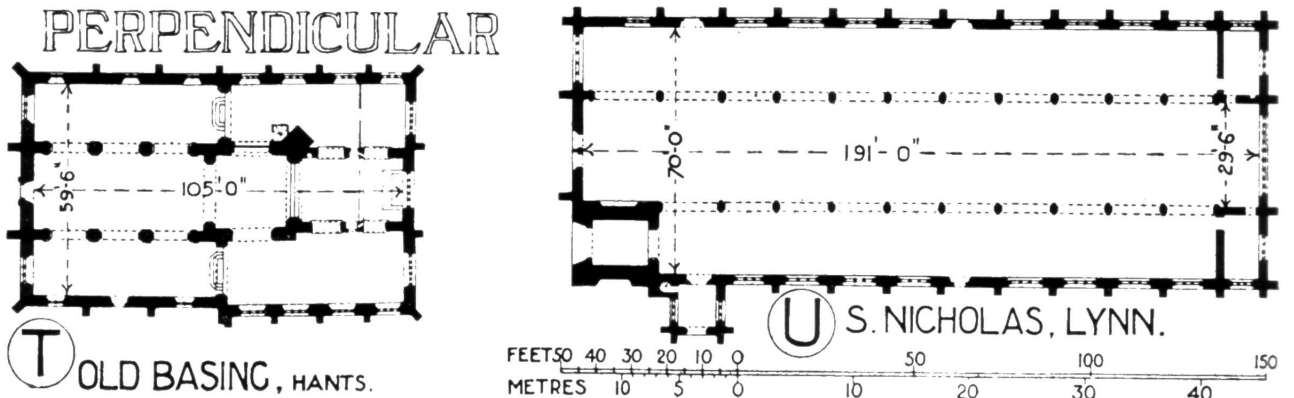

COMPARATIVE DOORWAYS

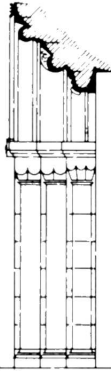
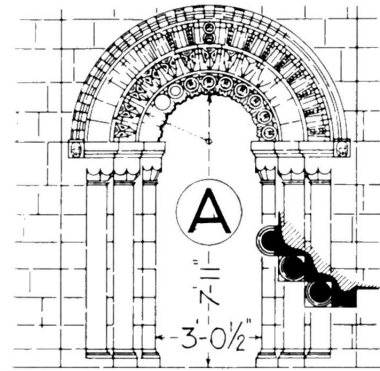

NORMAN **B** ARCH & JAMB MOULDINGS

ETTON CHURCH YORK-SHIRE

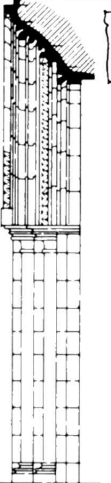
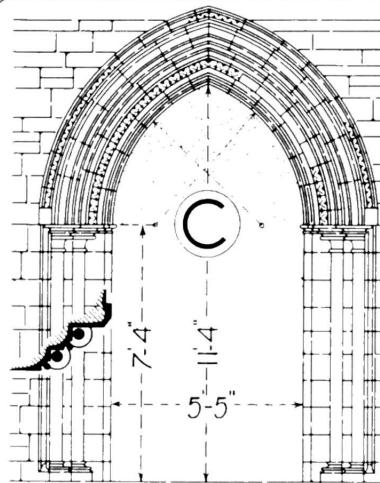
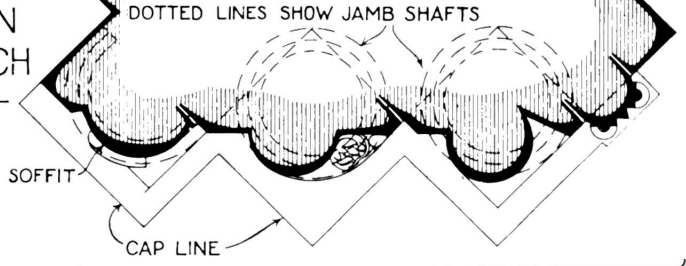

EARLY ENGLISH CLARE CHURCH, SUFFOLK.

E PLAN OF JAMB & ARCH MOULDINGS

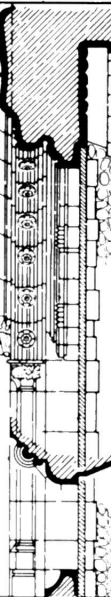
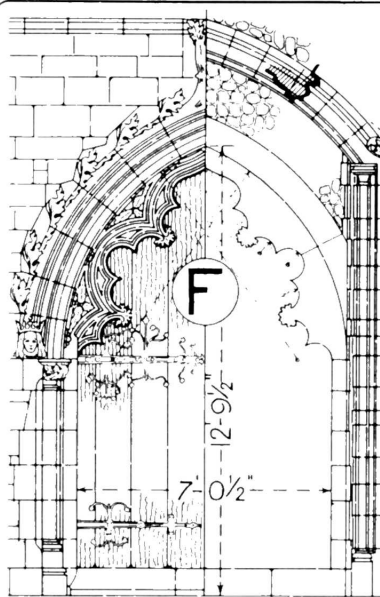
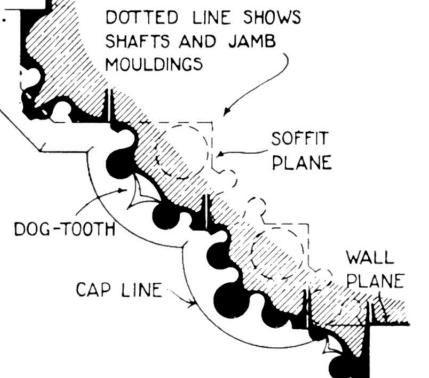
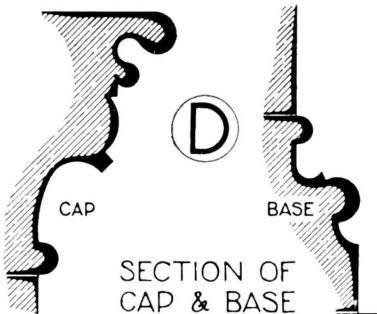

DECORATED ST JOHN'S CLEY, NORFOLK

H EXTERNAL BASE **K** INTERNAL CAP & BASE

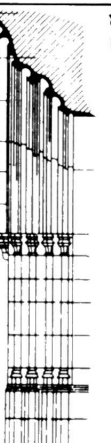
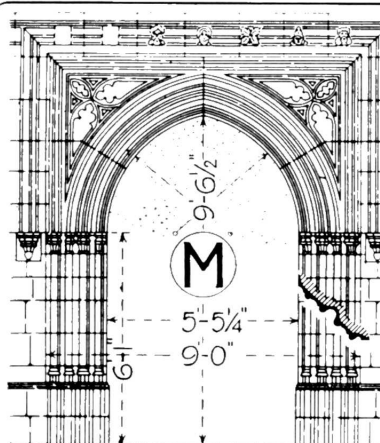
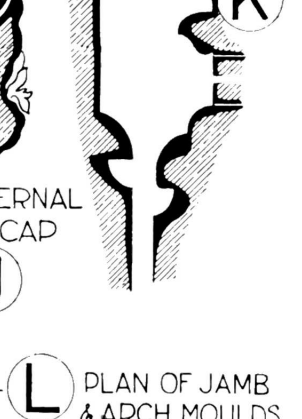
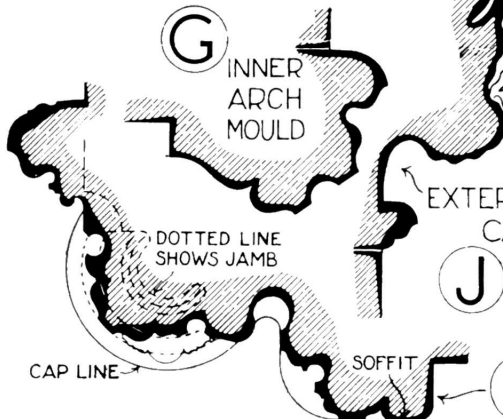

PERPENDICULAR MERTON COLLEGE, OXFORD.

P PLAN OF ARCH MOULDINGS

N SECTION THRO JAMB MOULDINGS

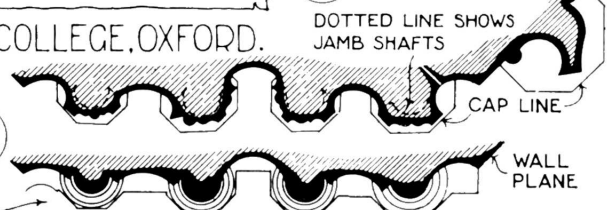

SCALE FOR ELEVATIONS 0 1 2 3 4 5 6 7 8 9 10 FEET
 SCALE FOR JAMB & ARCH MOULDINGS 12 9 6 3 0 12 INCHES
 SCALE FOR CAPS & BASES 0 1 2 3 4 5 6 7 8 9 10 11 12 13 14 INCHES

CROSSES, FINIALS, BOSSES, CORBELS, ETC.

CROSSES

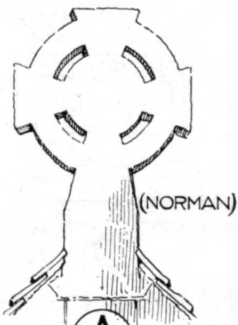

(NORMAN)
A
S. GERMAIN'S:
CORNWALL

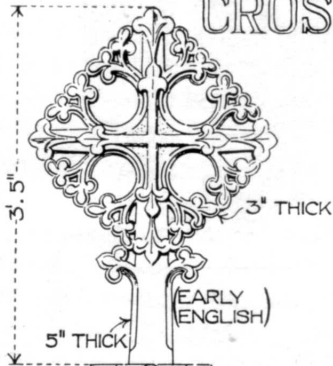

(EARLY ENGLISH)
B
WALSOKEN: NORFOLK

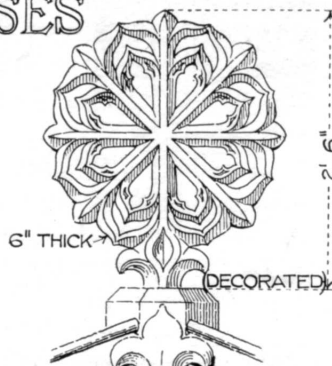

DECORATED
C
HASLINGFIELD: CAMBS.

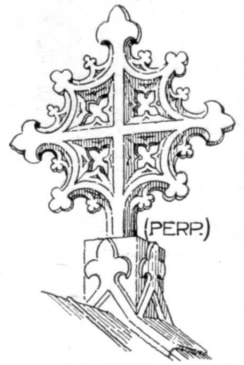

(PERP.)
D
TRUNCH:
NORFOLK

FINIALS

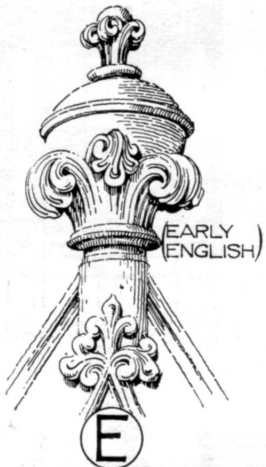

(EARLY ENGLISH)
E
LINCOLN CATH.

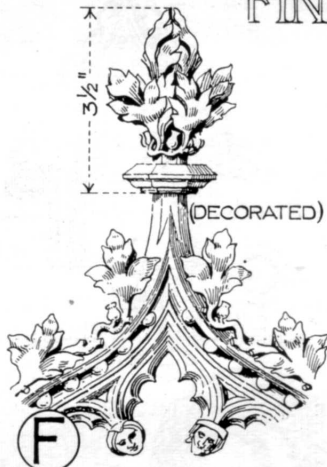

DECORATED
F
ALTAR SCREEN: BEVERLEY

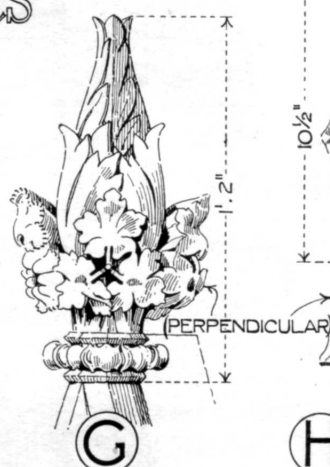

(PERPENDICULAR)
G
CHAPTER H^o: WELLS

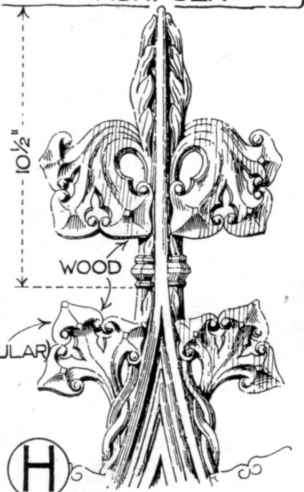

WOOD
(PERPENDICULAR)
H
CHOIR SCREEN: YORK

BOSSES

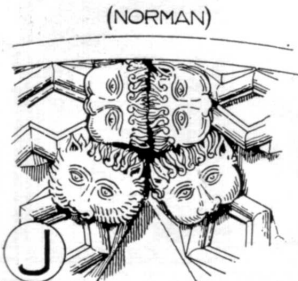

(NORMAN)
J
KILPECK: HEREFORD



(E. ENGLISH)
K
WESTMINSTER ABBEY



(DEC.)
L
BEVERLEY MINSTER

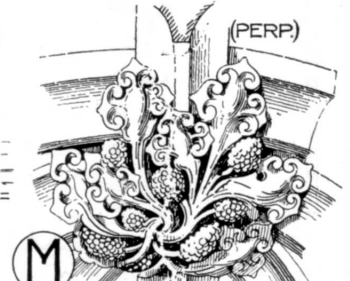

(PERP.)
M
MAGDALEN COLL.: OXON.

CORBELS & PENDANT



(NORMAN)
N
PRIOR'S DOORWAY:
ELY CATHEDRAL

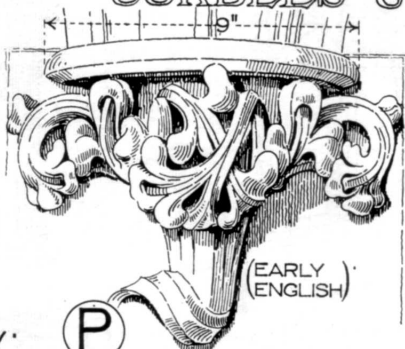

(EARLY ENGLISH)
P
S. ALBAN'S ABBEY

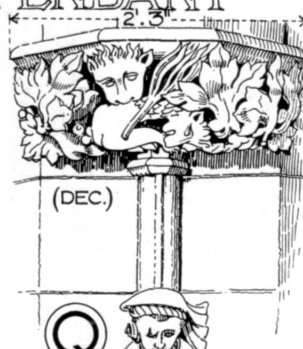

(DEC.)
Q
MAYOR'S CHAPEL: BRISTOL



(PERP.)
R
ALL SAINTS: EVESHAM

COMPARATIVE DOMES

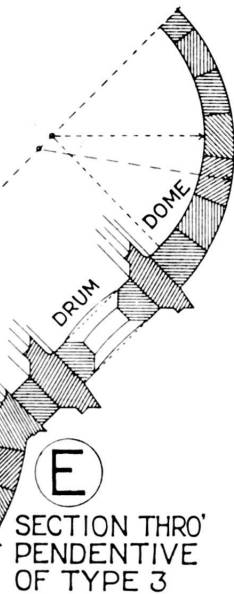
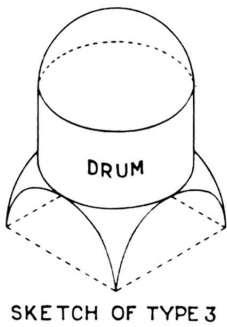
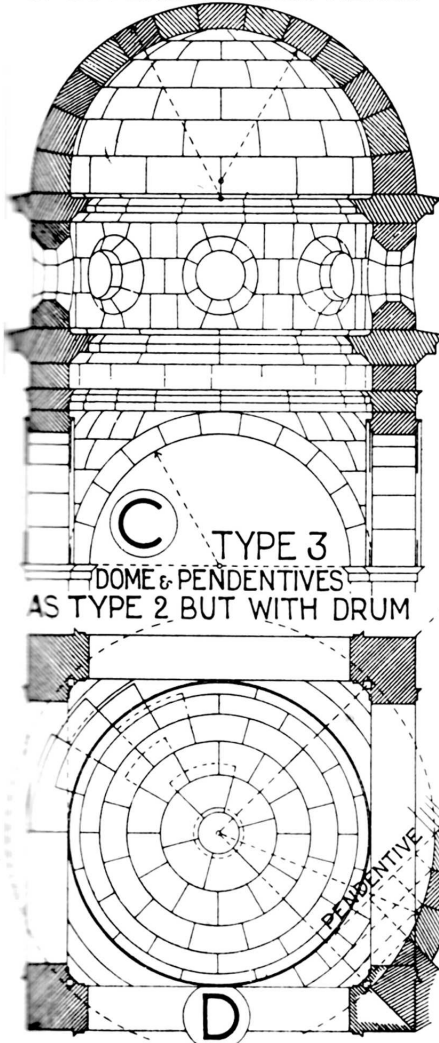
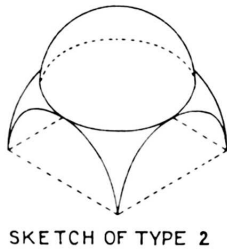
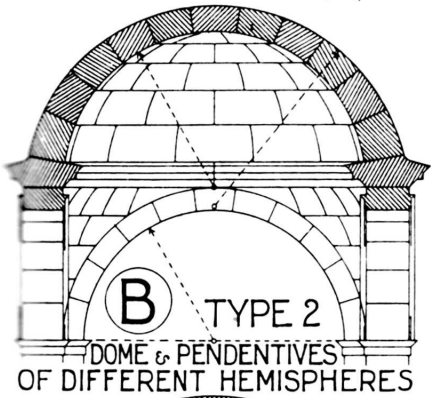
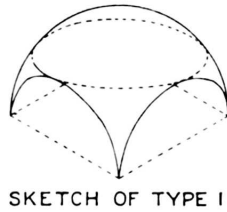
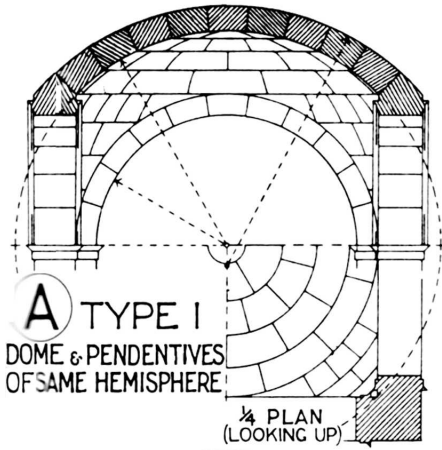

PLAN (LOOKING UP) FOR TYPES 2 & 3

B B

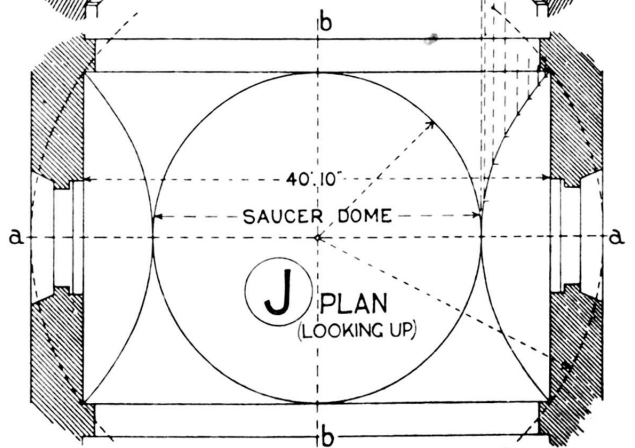
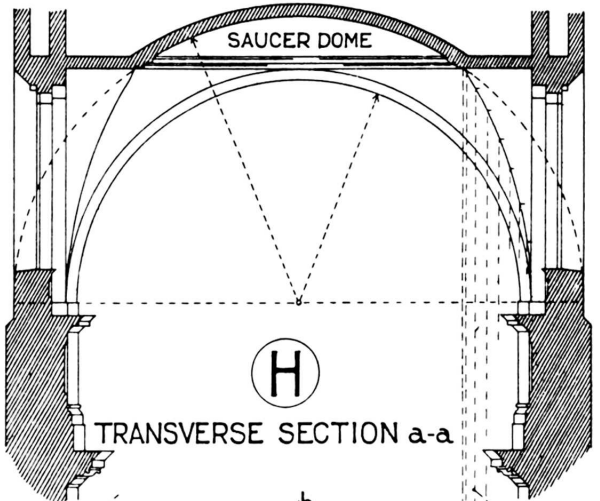
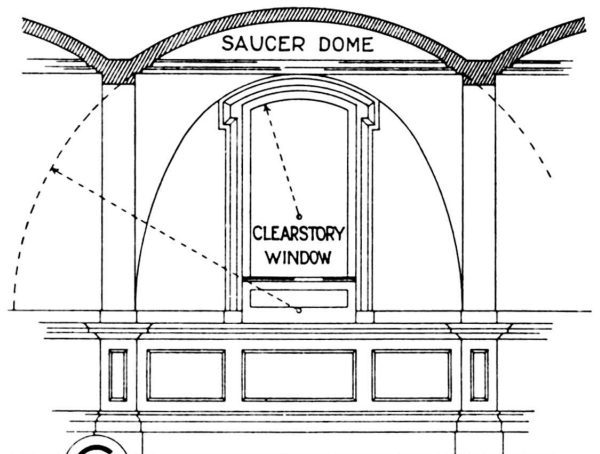
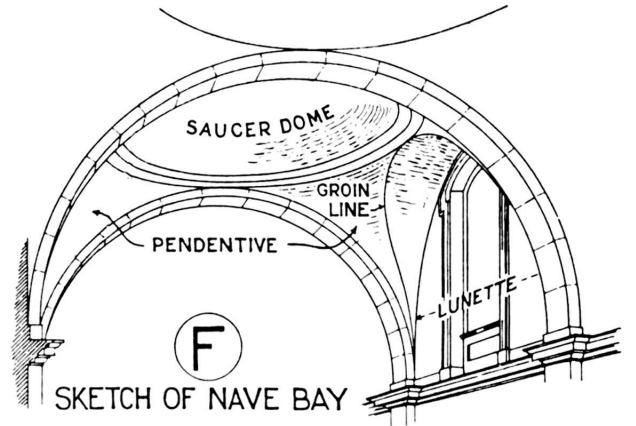

A NAVE BAY: S. PAUL: LONDON

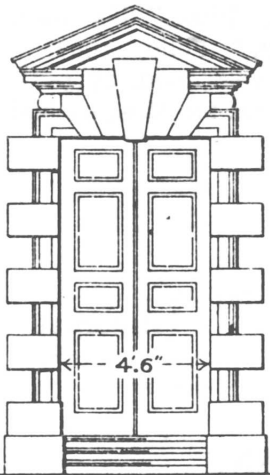

A DOORWAY: TYPE WITH RUSTICATED ARCHITRAVE

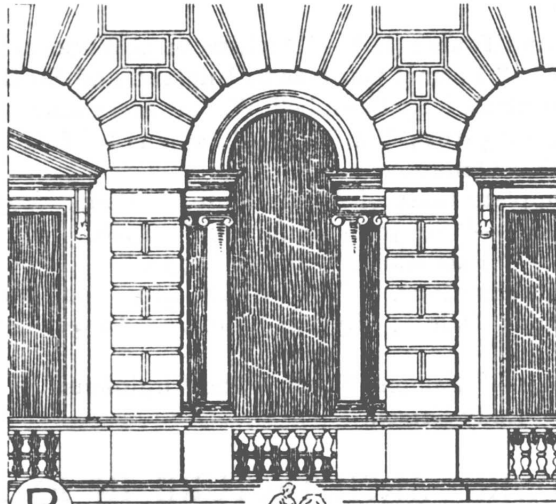

B TYPICAL WINDOW BY KENT LONDON
HORSE GUARDS

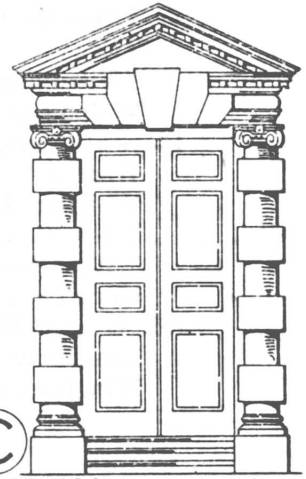

C DOORWAY: WITH RUSTICATED 3/4 IONIC COLS

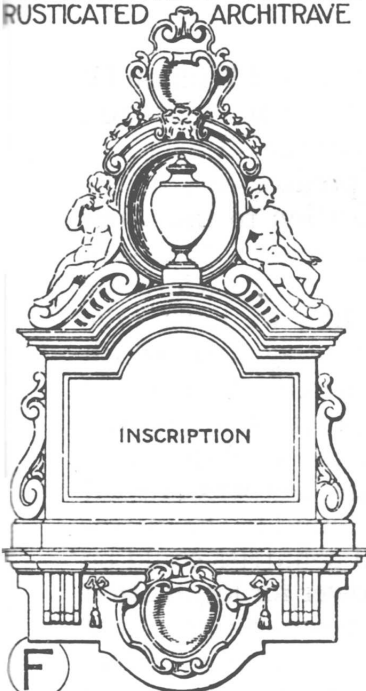

F MONUMENT TO SIR JOHN BRIDGMAN ASTON: WARWICKSHIRE



D ARCH WILTON
KEY PLAN
25.0'

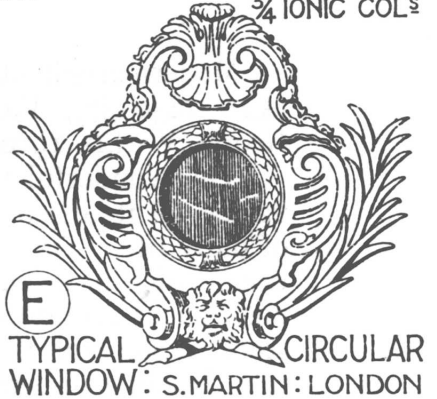

E TYPICAL CIRCULAR WINDOW: S. MARTIN: LONDON

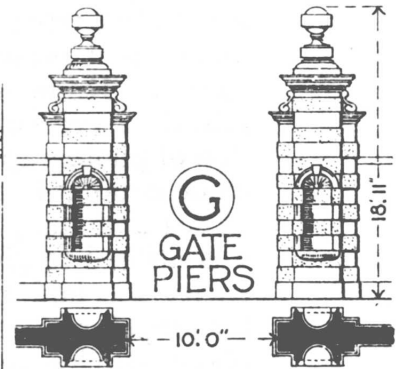

G GATE PIERS
18.11'
10.0'

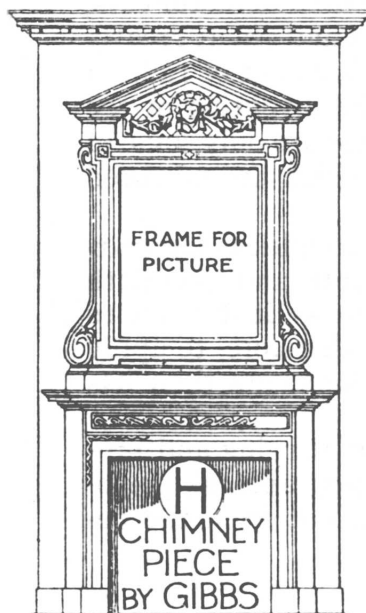

H CHIMNEY PIECE BY GIBBS

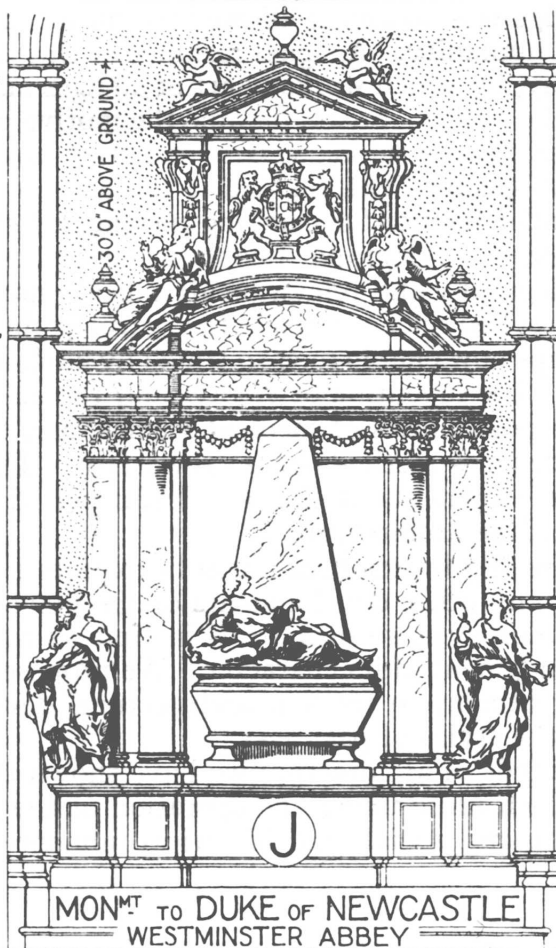

J MON^{MT} TO DUKE OF NEWCASTLE WESTMINSTER ABBEY
30.0' ABOVE GROUND

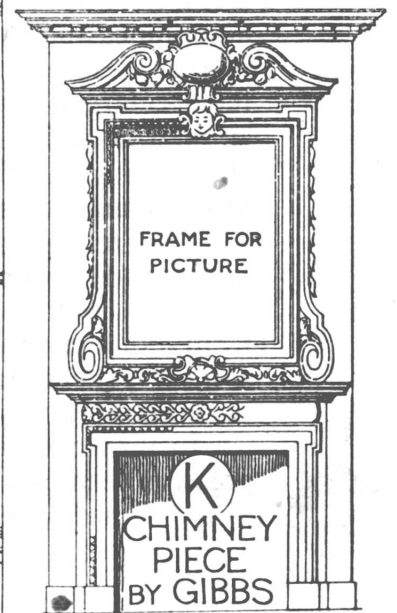

K CHIMNEY PIECE BY GIBBS

COMPARATIVE ARCHES

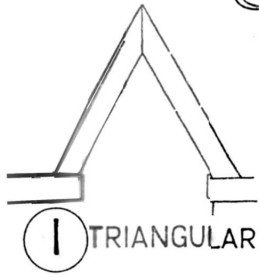

1 TRIANGULAR

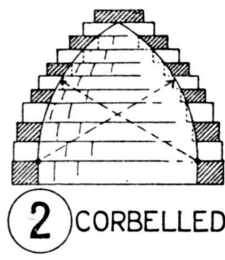

2 CORBELLED

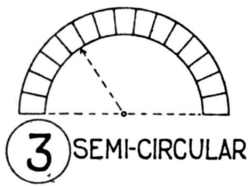

3 SEMI-CIRCULAR

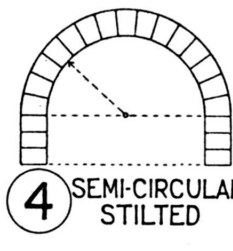

4 SEMI-CIRCULAR STILTED

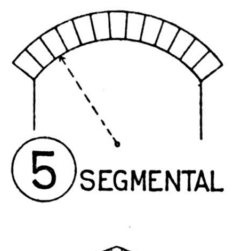

5 SEGMENTAL

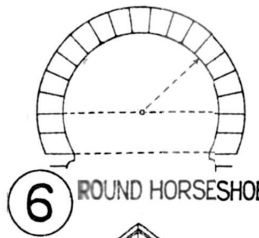

6 ROUND HORSESHOE



7 MOORISH MULTIFOIL

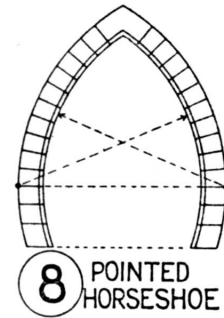

8 POINTED HORSESHOE

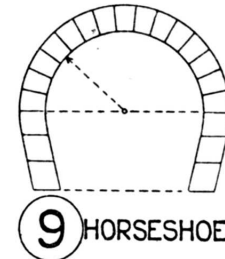

9 HORSESHOE

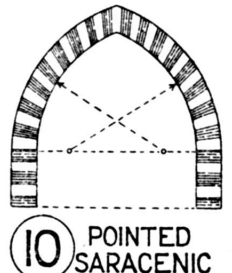

10 POINTED SARACENIC

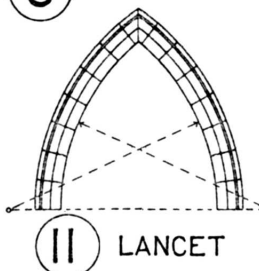

11 LANCET

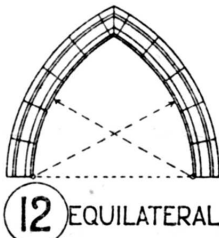

12 EQUILATERAL

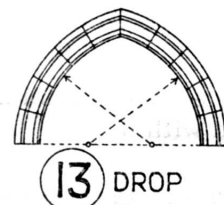

13 DROP



14 POINTED SEGMENTAL



15 THREE CENTRED



16 DEPRESSED THREE-CENTRED

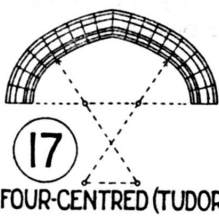

17 FOUR-CENTRED (TUDOR)

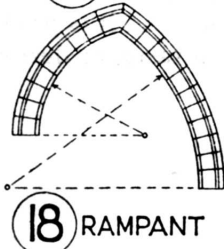

18 RAMPANT

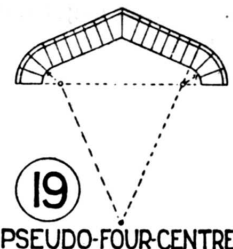

19 PSEUDO-FOUR-CENTRED

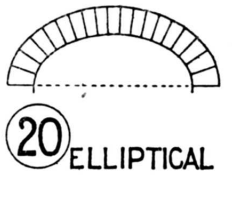

20 ELLIPTICAL

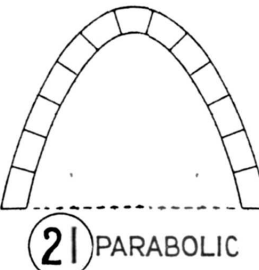

21 PARABOLIC



22 ROUND TREFOIL



23 POINTED TREFOIL



24 ROUND TRIFOLIATED



25 POINTED TRIFOLIATED

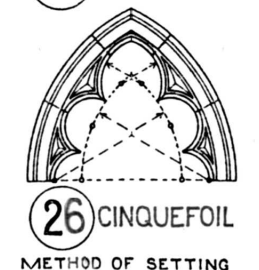

26 CINQUEFOIL



27 MULTIFOIL

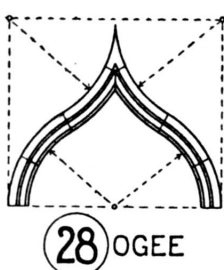

28 OGEE



29 OGEE



30 PSEUDO-THREE-CENTRED

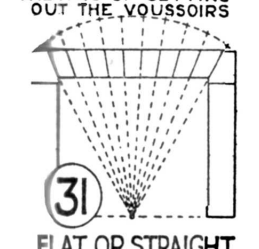

31 FLAT OR STRAIGHT



32 ITALIAN POINTED



33 VENETIAN



34 FLORENTINE

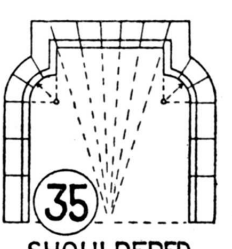

35 SHOULDERS

METHOD OF SETTING OUT THE VOUSOIRS

TEMPLE OF CASTOR & POLLUX: ROME

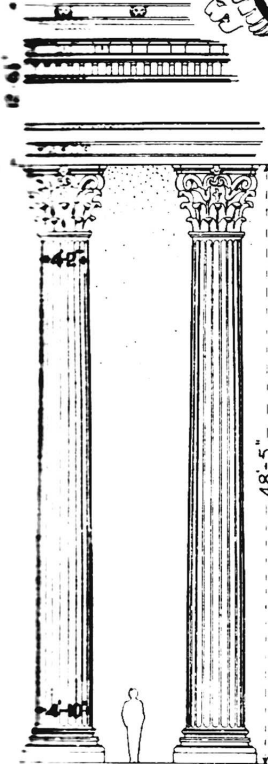

A ELEVATION OF ORDER

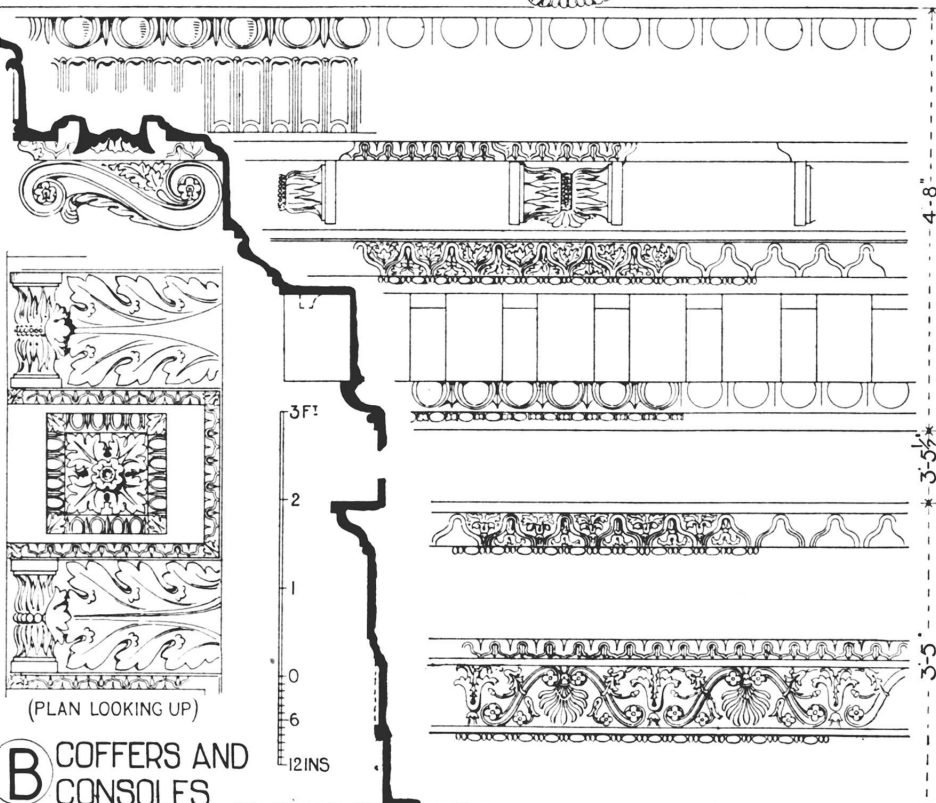

B COFFERS AND CONSOLES

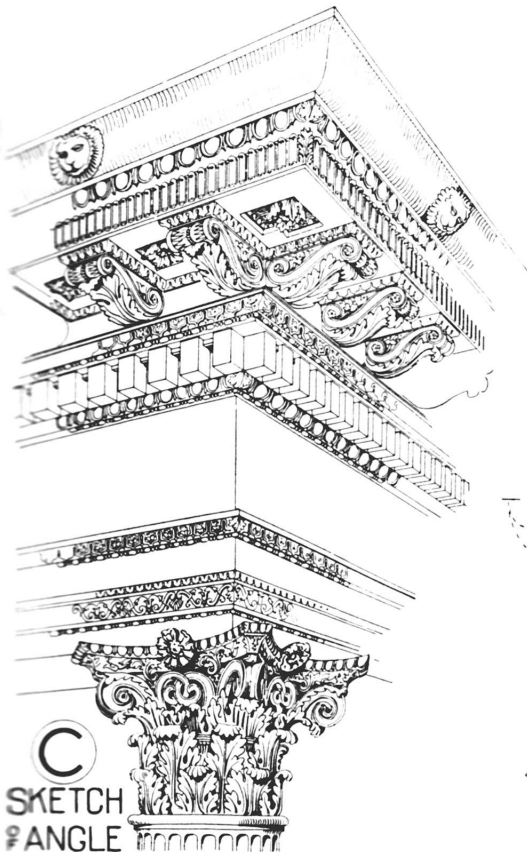

C SKETCH OF ANGLE

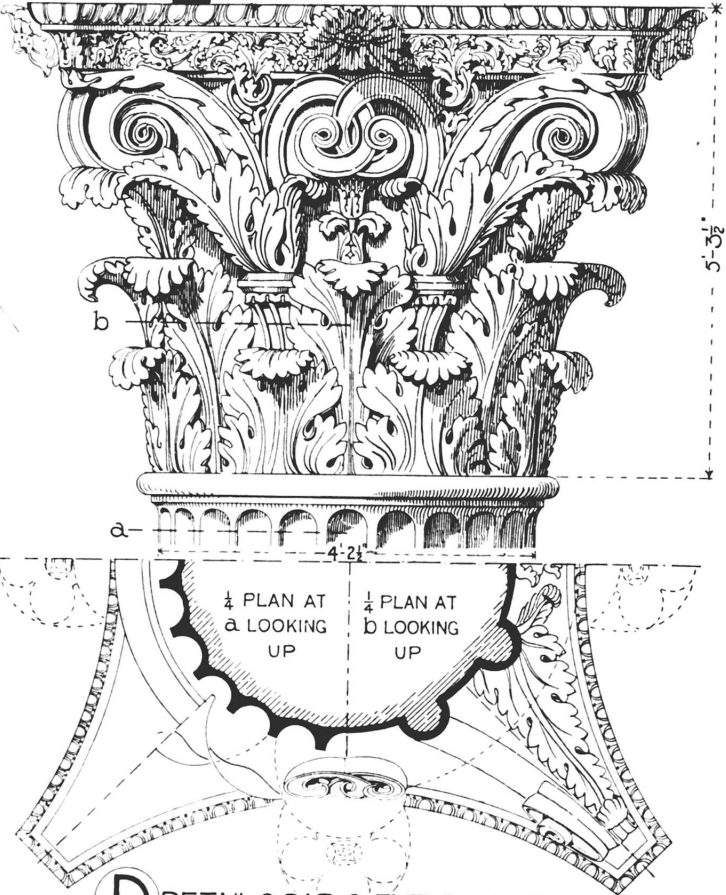

D DETAIL OF CAP & ENTABLATURE

COMPARATIVE DIAGRAMS OF VAULTS

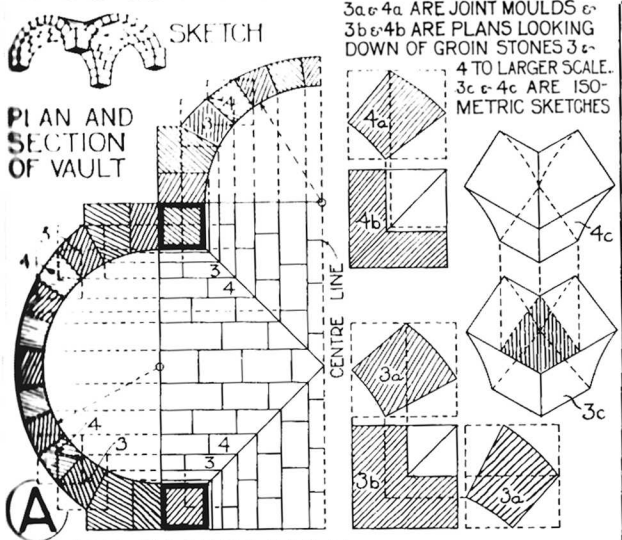

(A) ROMAN CROSS VAULT: THE COMPARTMENT IS SQUARE AND SEMI-CIRCULAR VAULTS OF EQUAL HEIGHT MAKE THE LINE OF GROIN STRAIGHT ON PLAN

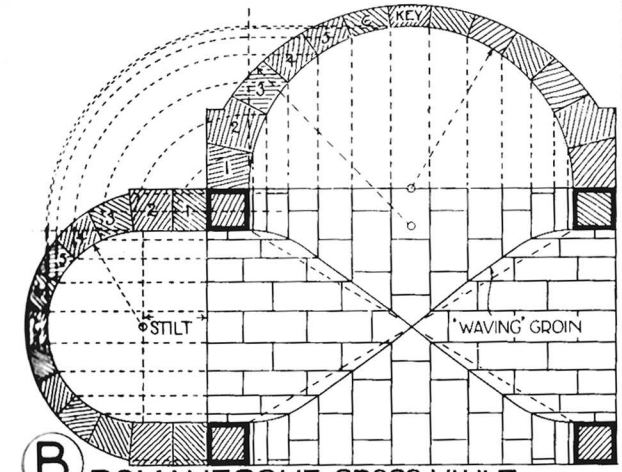

(B) ROMANESQUE CROSS VAULT: OBLONG COMPARTMENT & SEMI-CIRCULAR VAULTS OF UNEQUAL SPAN THE LESSER VAULTS STILTED MAKING LINE OF GROINS 'WAVING' ON PLAN

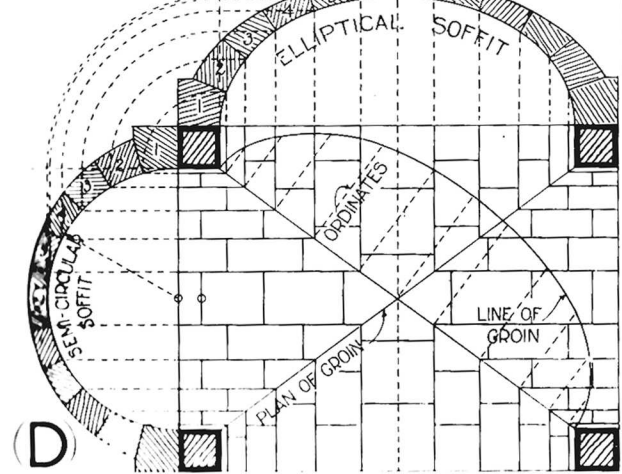

(D) RENAISSANCE CROSS VAULT: OBLONG COMPARTMENT & INTERSECTING VAULTS OF UNEQUAL SPAN BUT EQUAL HEIGHT OBTAINED BY USE OF CO-ORDINATES GROIN LINES STRAIGHT ON PLAN

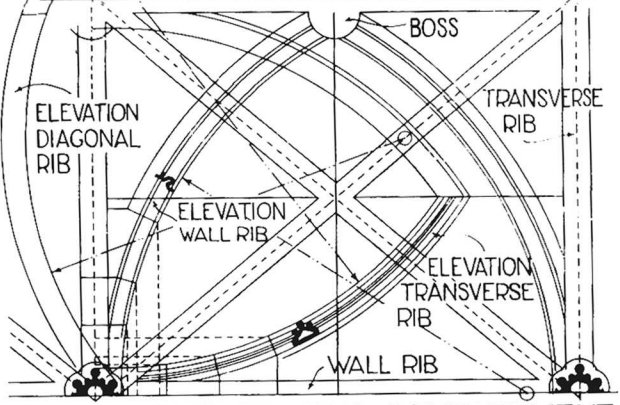

PLAN OF ONE VAULTING COMPARTMENT

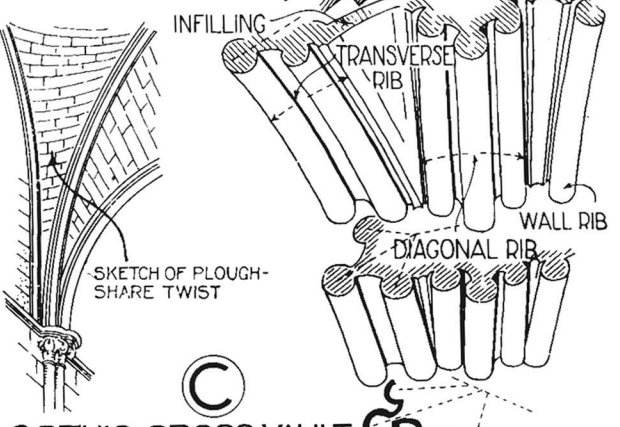
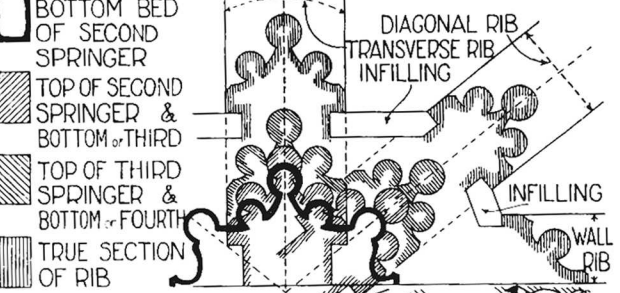

GOTHIC CROSS VAULT SOUTHWARK CATH^{DL}
SETTING-OUT OF TRANSVERSE, DIAGONAL & WALL RIBS

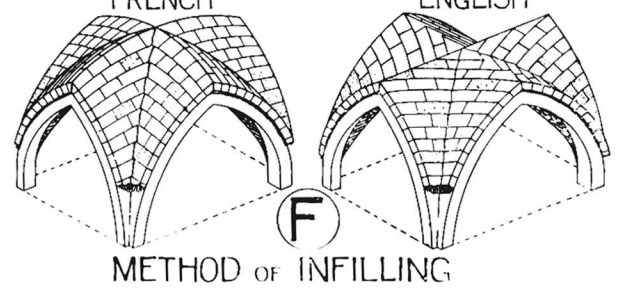
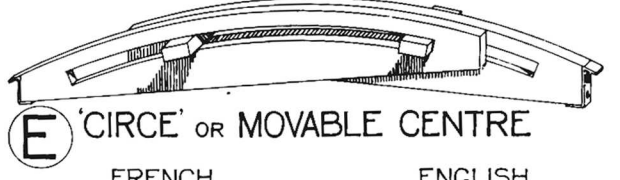

CROSSES, FINIALS, BOSSES, CORBELS, ETC.

CROSSES

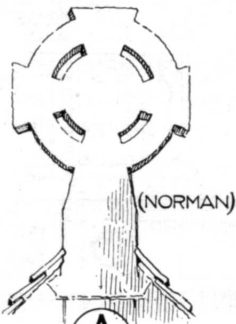

(NORMAN)
A
S. GERMAIN'S:
CORNWALL

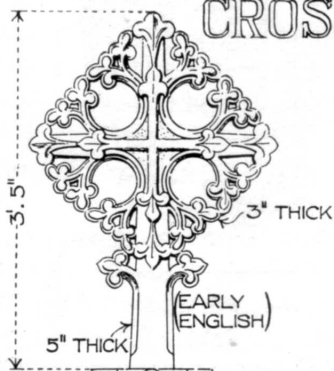

(EARLY ENGLISH)
B
WALSOKEN: NORFOLK

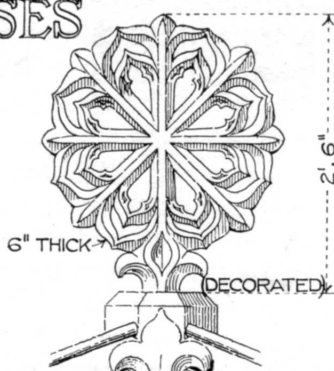

(DECORATED)
C
HASLINGFIELD: CAMBS.

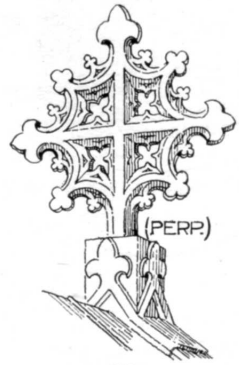

(PERP.)
D
TRUNCH:
NORFOLK

FINIALS



(EARLY ENGLISH)
E
LINCOLN CATH.

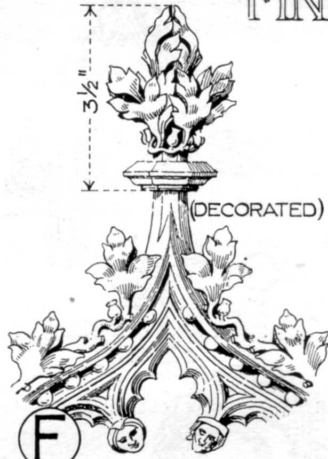

(DECORATED)
F
ALTAR SCREEN: BEVERLEY



(PERPENDICULAR)
G
CHAPTER H^o: WELLS

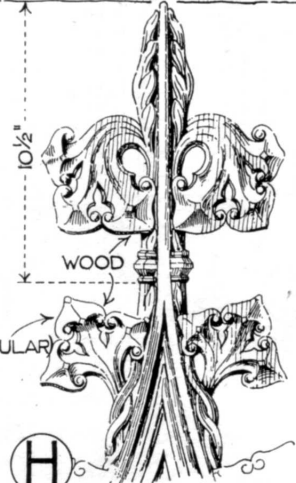

WOOD
H
CHOIR SCREEN: YORK

BOSSES

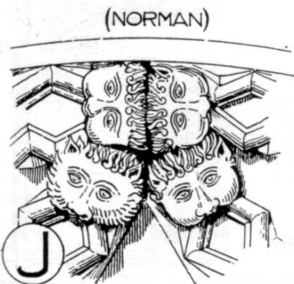

(NORMAN)
J
KILPECK: HEREFORD



(E. ENGLISH)
K
WESTMINSTER ABBEY



(DEC.)
L
BEVERLEY MINSTER

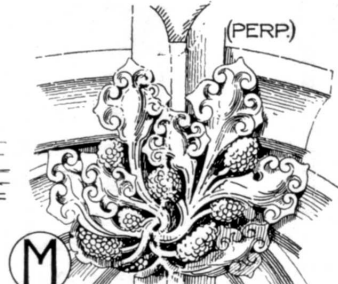

(PERP.)
M
MAGDALEN COLL.: OXON.

CORBELS & PENDANT



(NORMAN)
N
PRIOR'S DOORWAY:
ELY CATHEDRAL

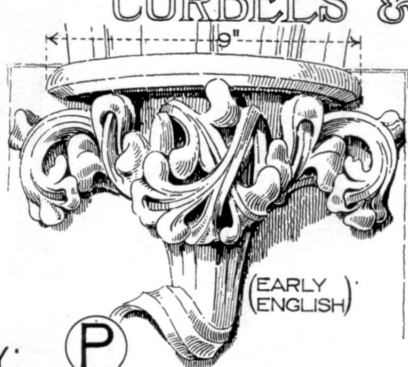

(EARLY ENGLISH)
P
S. ALBAN'S ABBEY

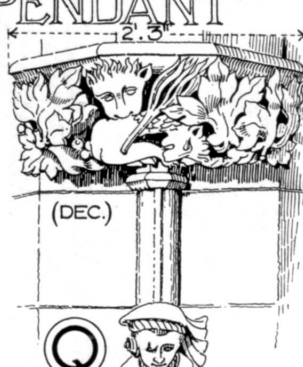

(DEC.)
Q
MAYOR'S CHAPEL: BRISTOL



(PERP.)
R
ALL SAINTS: EVESHAM

COMPARATIVE WINDOWS

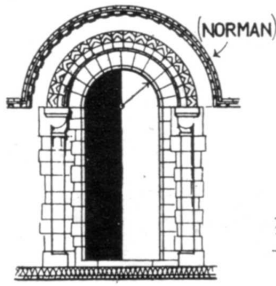

A WALTHAM ABBEY

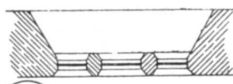
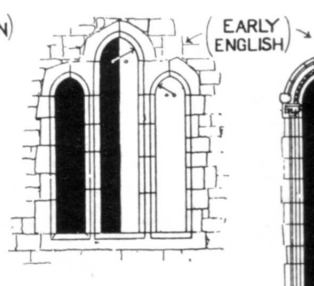

B WIVELSFIELD SUSSEX

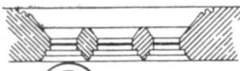
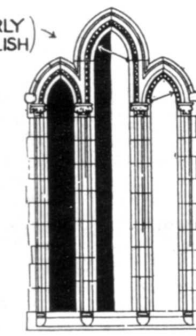

C WILEY WILTS

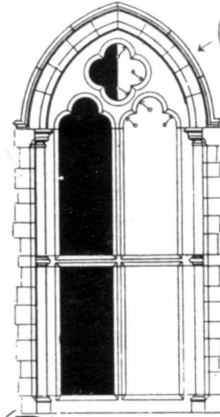

D CASTLE HALL WINCHESTER

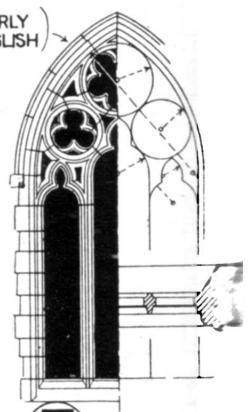

E MEOPHAM KENT

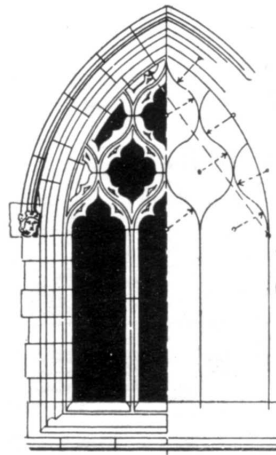

H S. MARY MAGDALEN CHURCH : OXFORD

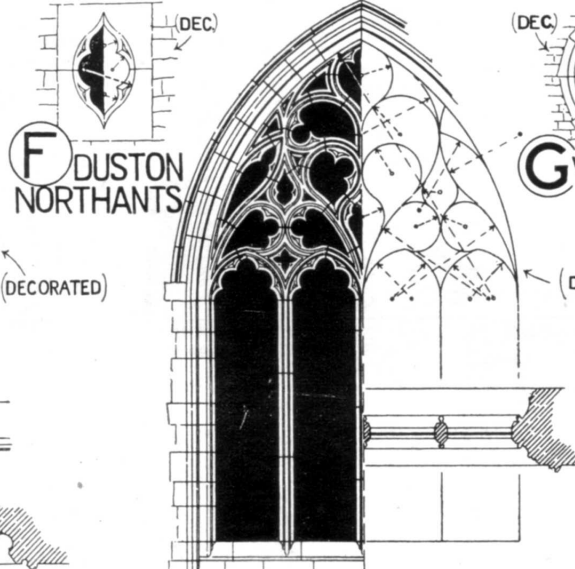

J HOLBEACH CH. : Lincs



G WALTHAM ABBEY

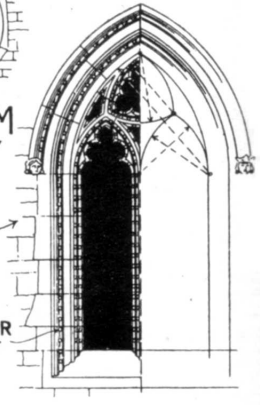

BALL FLOWER ORNAMENT

K BADGEWORTH : GLOS

SCALE FOR ALL THE WINDOWS EXCEPT (M)

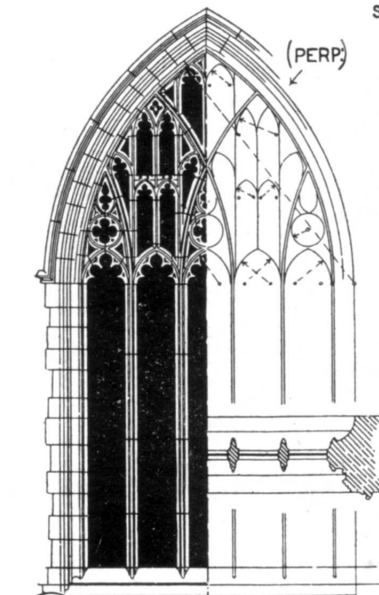

L WAWN : YORKS

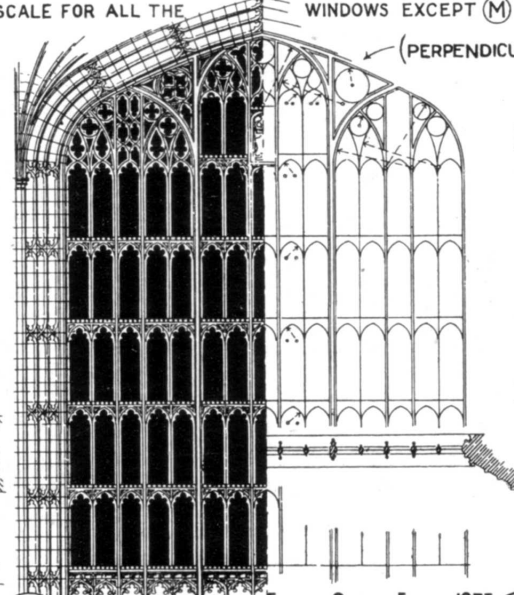

M S. GEORGE'S CHAPEL : WINDSOR

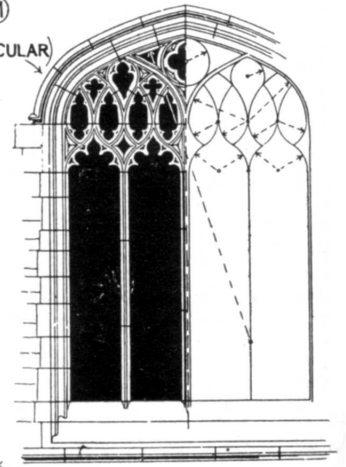

N S. MICHAEL : BASINGSTOKE

COMPARATIVE MOULDINGS

NORMAN

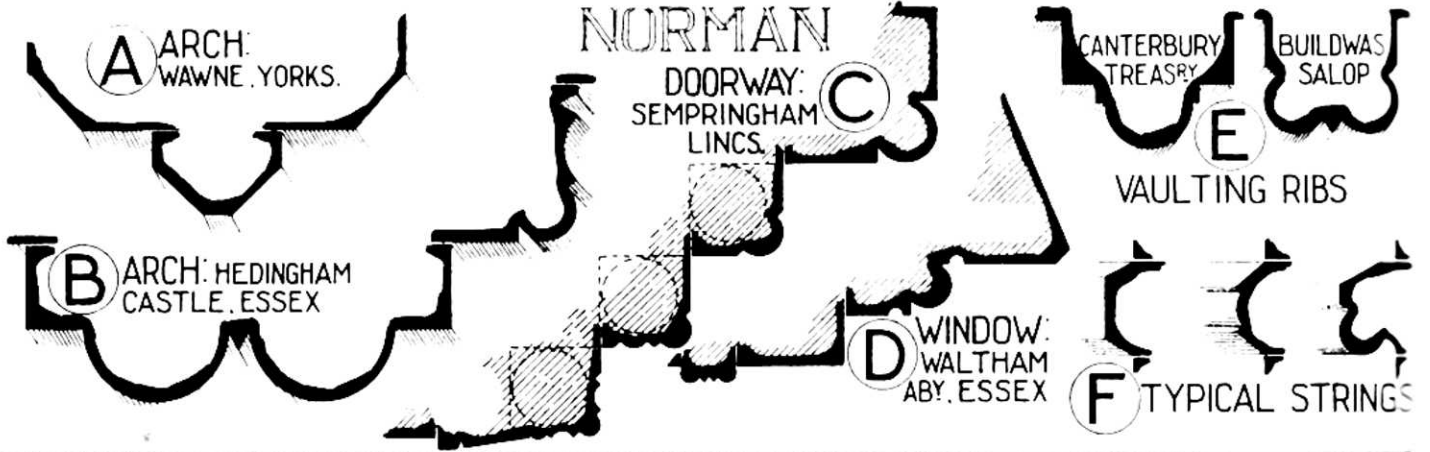

EARLY ENGLISH

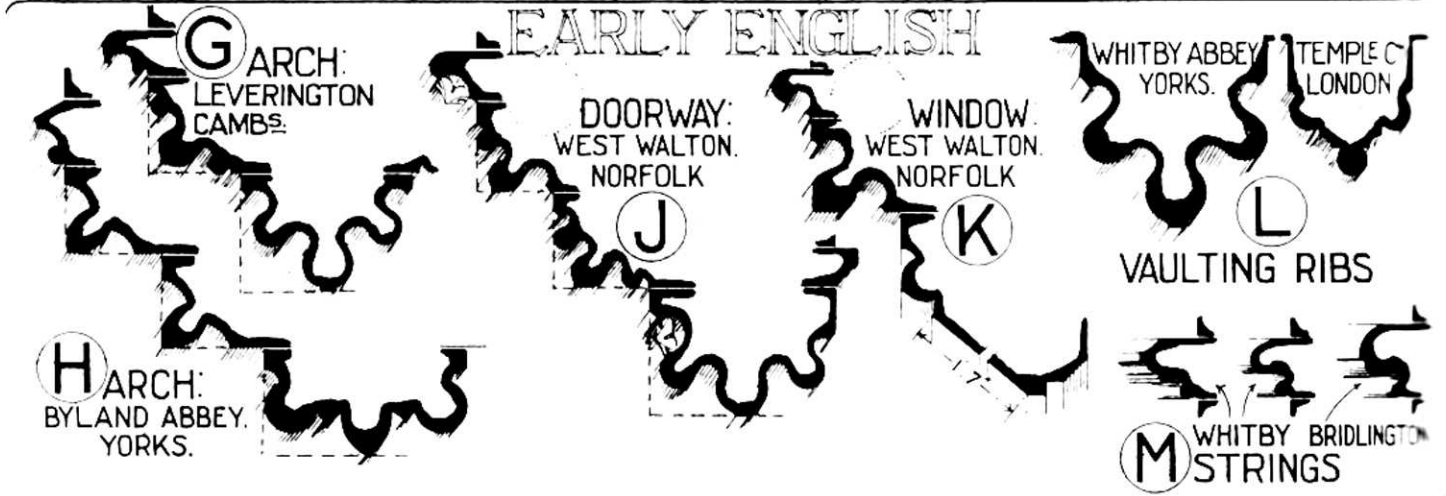

DECORATED

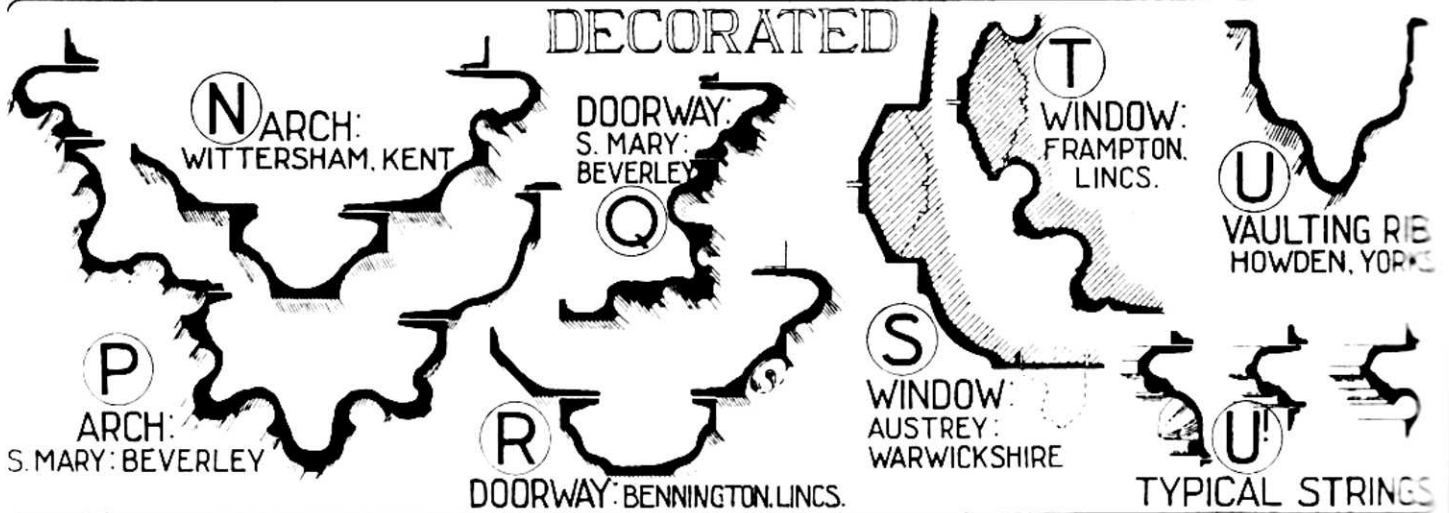

PERPENDICULAR

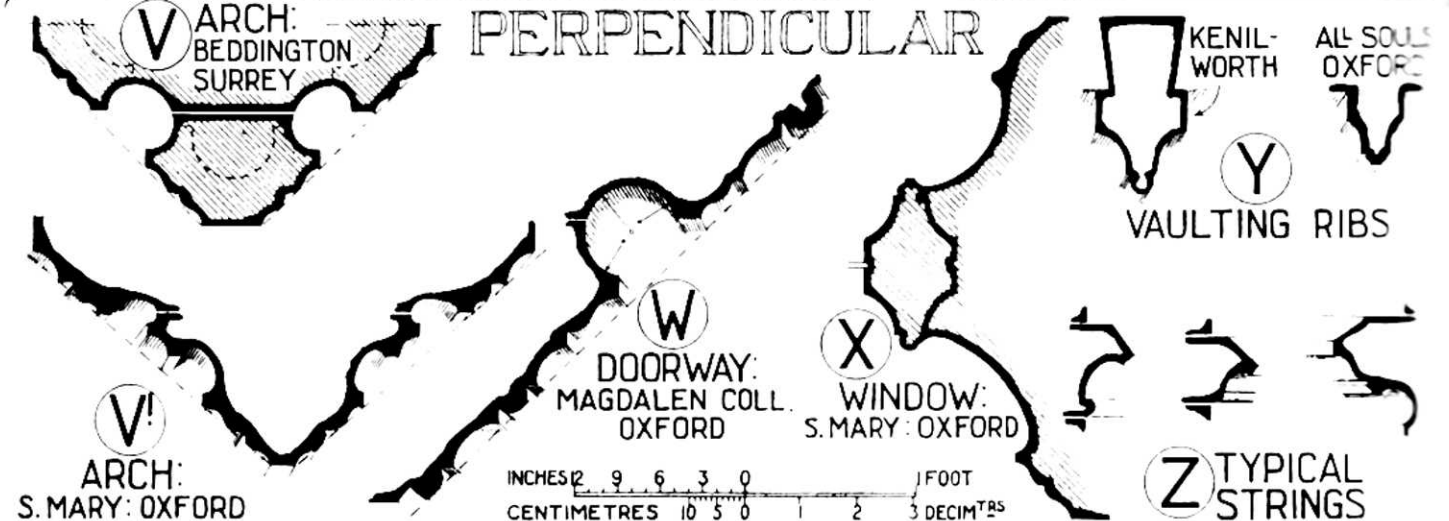

INCHES 12 9 6 3 0 / FOOT
 CENTIMETRES 10 5 0 1 2 3 DECIM^{TS}



TURRET: PEMBROKE COLL. CAMBS.

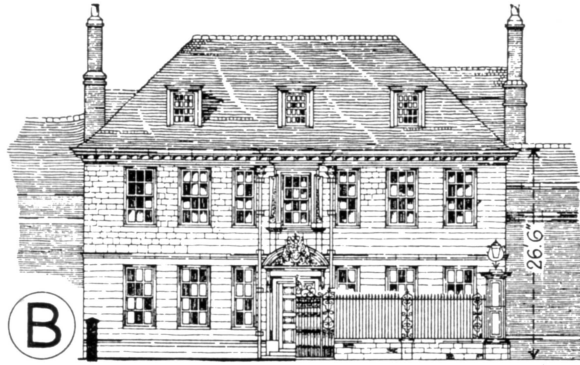

HOUSE IN CLOSE: SALISBURY

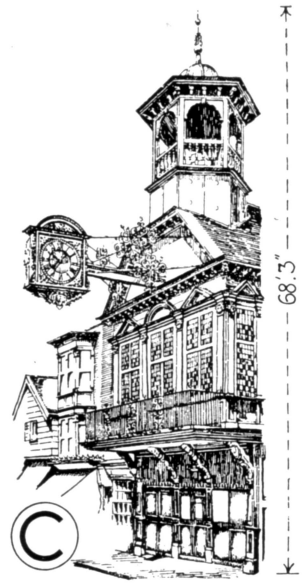
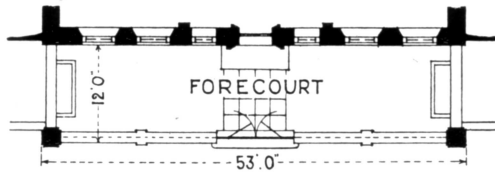

TOWN HALL: GUILDFORD

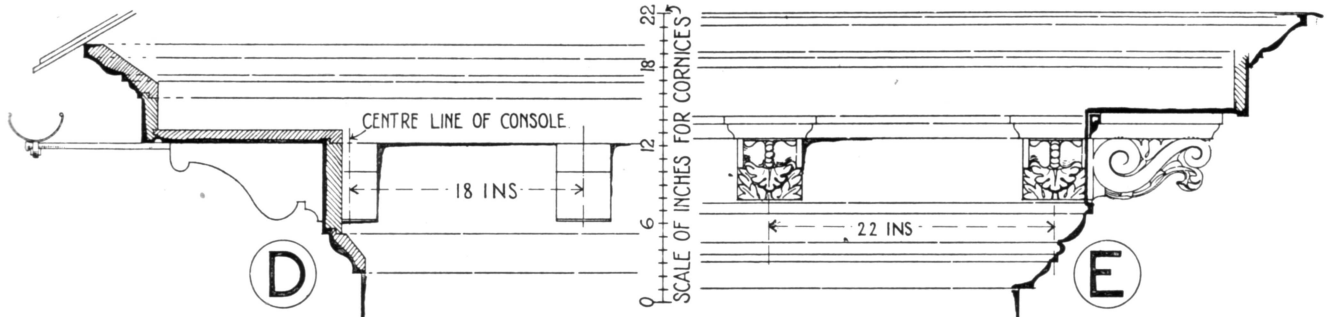

CORNICE: S. GEORGES SQ. STAMFORD

CORNICE: MORDEN COLL. BLACKHEATH

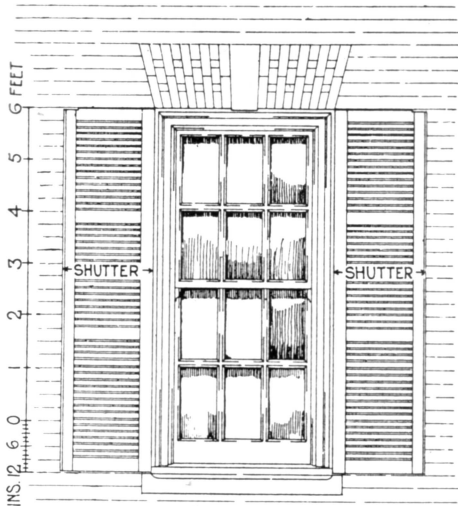

ELEVATION GEORGIAN SASH WINDOW

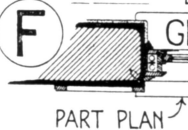

PART PLAN

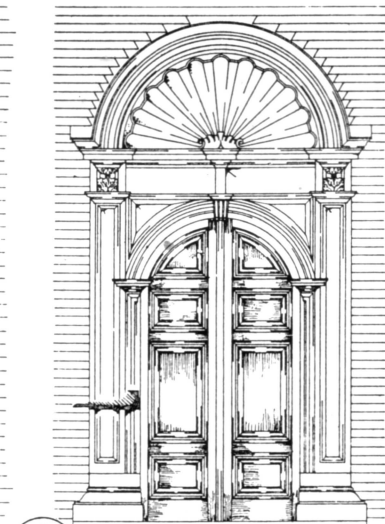

DOORWAY: HAMPSTEAD



PLAN LOOKING UP SECTION

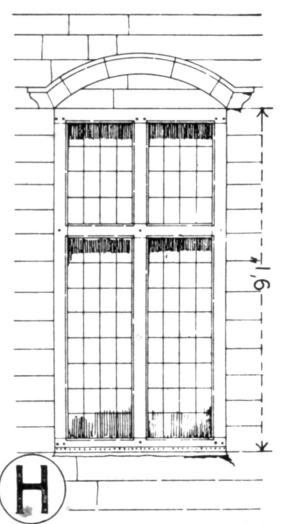

CASEMENT WINDOW WOLVESEY PAL. WINCHESTER

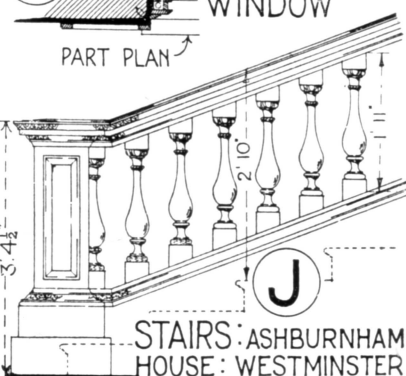

STAIRS: ASHBURNHAM HOUSE: WESTMINSTER

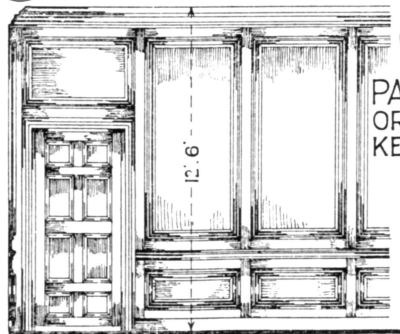

PANELLING ORANGERY KENSINGTON

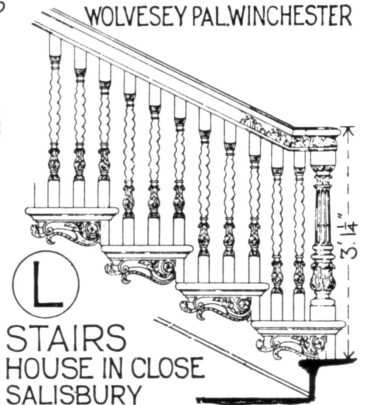

STAIRS HOUSE IN CLOSE SALISBURY